

2 x \varnothing 18 THRU ALL

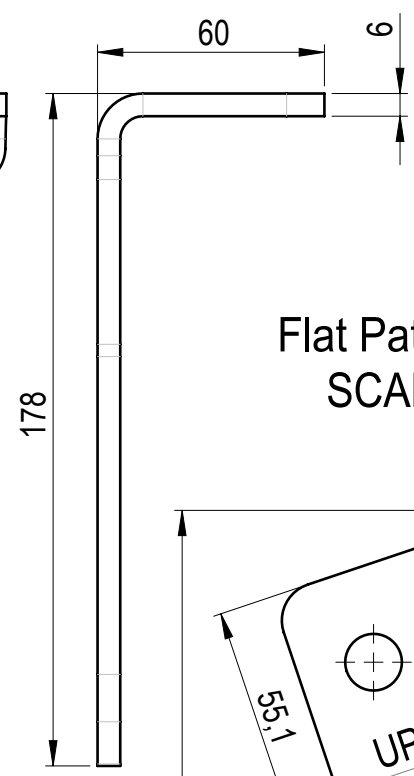

Flat Pattern view
SCALE: 1:2

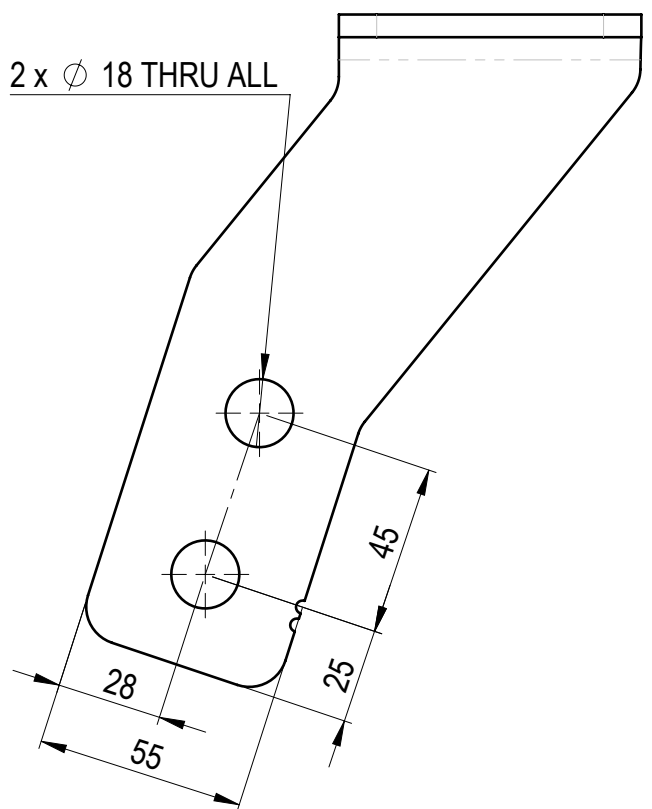
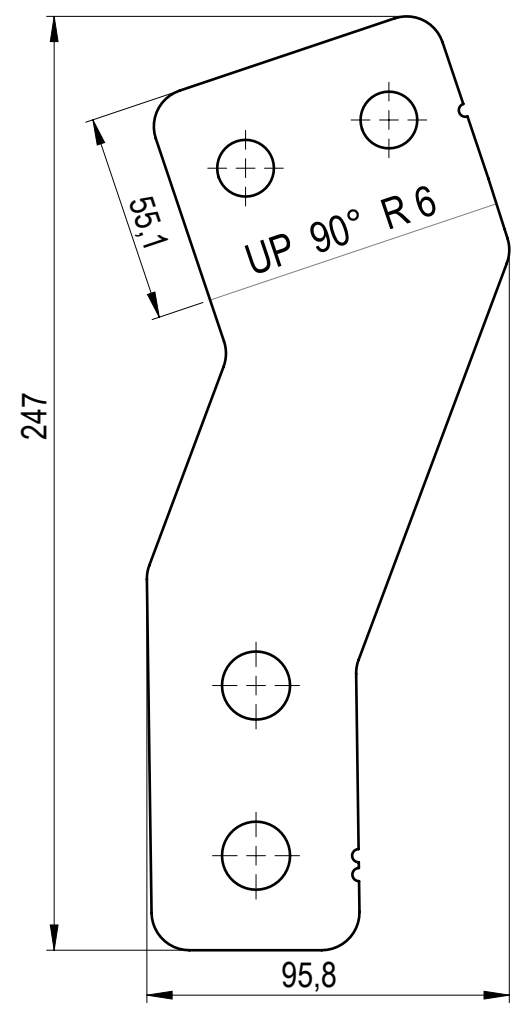

2 x \varnothing 15 THRU ALL

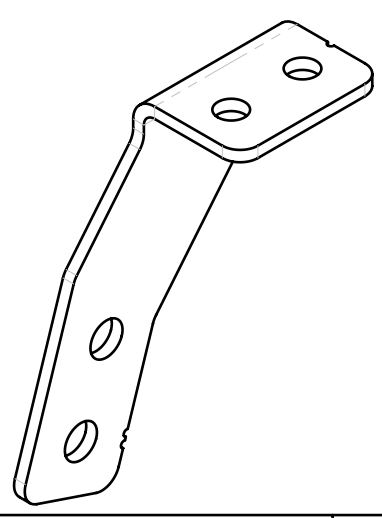
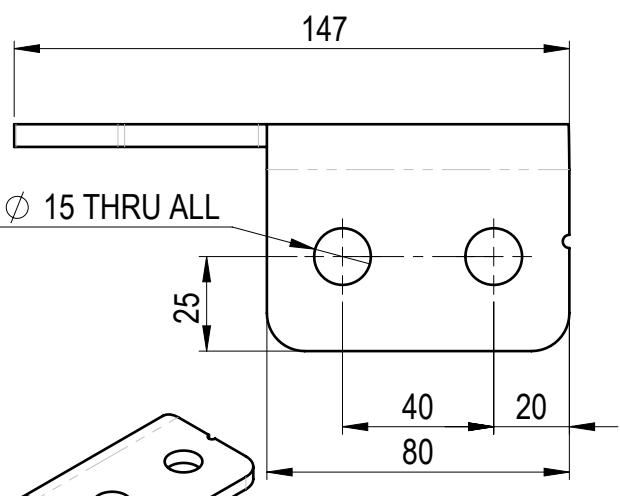

Other dimensions from DXF file

SHEET METAL INFORMATION	
Length, mm	247.8
Width, mm	94.5
Thickness, mm	6
Inside Bend Radius, mm	6
K-Factor	0.5
No. of Bends	1

	MATERIAL	S355J2	WEIGHT	0.693 Kg	DEBURR AND BREAK SHARP EDGES DO NOT SCALE DRAWING	REVISION	DATE		
	SURFACE PROTECTION	HDG EN ISO 1461	MACHINING	ISO 2768 mK	THERMAL CUTTING	ISO 9013 221	WELDING	ISO 13920 BF	SCALE
NAME	SIGNATURE	PART NO.		105-09100-69					
Designed by	D. Dislers	DESCRIPTION		Left bracket HU				SHEET 1/1	
Drawn by	D. Dislers								
Technical ref.									